A Biological Perspective on Sorting with P Systems

Ioan I. Ardelean^{1,2}, Rodica Ceterchi^{*3}, Alexandru Ioan Tomescu³

¹ Institute of Biology, Romanian Academy
Centre of Microbiology, Splaiul Independentei 296
P.O. Box 56-53, Bucharest 060031, Romania

² Ovidius University, Constanta, Romania

³ Faculty of Mathematics and Computer Science, University of Bucharest
Academiei 14, RO-010014, Bucharest, Romania
E-mails: ioan.ardelean@ibiol.ro, rceterchi@gmail.com,
alexandru.tomescu@gmail.com

Summary. The aim of this contribution is to argue that the processes occurring in biological membranes in bacteria are also important as natural examples of communication between membranes, which, in the formal framework of P systems, leads (among other things) to simulations of sorting operations.

1 Introduction

Sorting is one of the most studied problem in Computer Science, as it has a wide range of applications, including sequential and parallel algorithms. Static sorting algorithms have been developed and proposed also in the P systems area. Among the first approaches, made independently, we mention [6] and [10], [11]. The problem of sorting with P systems occupies Chapter 8, [1], of the monograph [12].

The aim of this contribution is to show that the processes occurring in biological membranes in bacteria (cell membrane, external membrane or intracellular vesicles) which are essential for cell life being, are also important as natural examples of sorting processes occurring in bacteria. The argument is presented in Section 2. Accordingly, we have abstracted a formal model for a comparator of two values, which uses 3 membranes and communication rules between them. From the formal point of view, an immediate generalization follows, for N arbitrary values, whose biological feasibility remains to be investigated, and is probably heavily dependent on the value of N . Along the lines of previous work on sorting with membranes, a system is proposed to sort 4 values, by simulating a sorting network with 4 wires. This is the content of Section 3.

* Corresponding author

2 Biochemical Reactions

Biochemical reactions in living cells occur following precise rules and laws; one rule shows that in a given chemical reaction there is a given numerical proportion between the reactants.

Respiration is the biological process that allows the cells (from bacteria to humans) to obtain energy. In short, respiration promotes a flux of electrons from electron donors to a final electron acceptor, which in most cases is molecular oxygen. The ability of many bacteria to use molecular oxygen as final electron acceptor in their respiration is provided by the work of an enzyme named: cytochrome *c* oxidase which catalyzes the following equations:

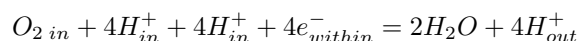

The subscript “in” means on the inner face of the membrane, “out” the outer face of the membrane while “within” simply means within membrane.

Thus, during the last step of respiration shortly presented above, water is formed from molecular oxygen, protons ($4H^+$) and electrons ($4e^-$). 4 protons are simultaneously transferred across membrane from inside to outside the cell contributing to energy conservation. Apart from its biological significance, the function of cytochrome *c* oxidase could offer to P system scientists an example of a new type of developmental rule more complex than those already taken into account [18]. In a general formulation this rule is:

$$A_{in} + B_{in} + C_{within} = D_{in} + B_{out}$$

Moreover, coefficients before the symbols could be of help in establishing whether or not the function of cytochrome *c* oxidase could be used for sorting.

The overall process of photosynthesis as it occurs in cyanobacteria (as well as in algae and plants) consists in using electrons from water to ultimately reduce carbon dioxide thus forming substances such as carbohydrates. This process is essential for the life on Earth, being the main energy source for almost all living cells, including humans, the only source of molecular oxygen needed for respiration (and many oxygen-consuming related activities) as well as a huge carbon dioxide-consuming process.

The first major event in photosynthesis is the splitting of water at the expense of light energy to molecular oxygen, protons and electrons, which occurs at the level of intracytoplasmic vesicles called thylakoids. To be more precise, we focus on cyanobacteria which are Gram-negative bacteria, and we recall a few structural aspects of these bacteria which are relevant for sorting.

In Gram-negative bacteria, apart from the cell membrane (CM) covering the cytoplasm, there is a second membrane, called external membrane (EM), because it is located at the exterior of the cell membrane; the space between these two membranes is called periplasmic space.

The two membranes, EM and CM with a structure described by the fluid mosaic model, have different chemical composition and different particularization of the functions. When it comes to the transport of ions and molecules across them there are some important differences. Inorganic ions for example, can pass through the EM while there are special proteins and mechanisms controlling their passage across CM (see below).

Apart from CM and EM in some bacteria inside the cell there are some intracellular membranes (IM) organized in very tiny vesicles, these structures being associated with specific metabolic functions, photosynthesis being the most important.

Notwithstanding its biological significance, the splitting of water could offer to P system scientists an example of a new type of developmental rule more complex than those already taken into account, with applications, for example, in sorting with P systems. In photosynthesis, there is a movement of molecules and ions across the cytoplasmic membrane (skin membrane) the intrathylakoidal space to cytoplasm which could be interesting to be studied from the point of view of sorting.

For P systems symport and antiport rules are nice examples of how bacterial cells manage the developmental rules [18, 19]. In Bacteria these processes are needed to transport useful substances inside the cell and to transport outside the cell toxic substances, thus maintaining intracellular composition stable in a changing environment.

Another important transport system used by bacteria, is TRAP (tripartite ATP independent periplasmic) transporters [13]. Mechanistically TRAP systems are symporters transporting across CM protons and one solute (glutamate, for example). However, the significant differences with respect to a pure symport system, is that the transport of the solute takes place only when a specific periplasmic protein to bind the solute is present. So, there is the control of the transport of solute, carried out by a specific periplasmic protein that does not cross the CM! For P systems, the transport of a solute, chemical species controlled by another component, not passing through the membrane could be important for in vitro implementation of sorting.

The incorporation of different active (mainly) protein molecules in artificial membranes opens the possibility to move objects across these membranes. In our opinion, these experiments (with antiporters, symporters or any other active molecule biologically produced or chemically synthesized, but arranged in an appropriate way within the artificial membrane) could be useful for P systems for molecule sorting. Furthermore, in artificial membranes one could incorporate molecules which function as molecular logic gates such as those active in respiration [5]. Moreover, very recent results show that it is possible to improve the structure of artificial vesicle membranes by coating hollow polyelectrolyte capsules with biological interfaces such as phospholipid membrane and proteins [15], a step toward an artificial cell assembly [16]. The results in artificial membrane

research support the hope that they are appropriate tools for sorting experiments proposed in this contribution.

3 The Abstract Model for Sorting

Comparison-based sorting has been previously addressed in the field of P systems [1, 9]. Although it is well known that such sequential sorting algorithms require at least $N \log N$ comparisons to sort N items, performing many comparisons in parallel can reduce the sorting time. For example, the bitonic sorting algorithm proposed by Batcher [7] has complexity $O(\log^2 N)$. The intrinsic parallelism of P systems leads to a natural adaptation of classical parallel algorithms, which has been exploited in [9]. The P system consisted of a 2D-mesh of $\sqrt{N} \times \sqrt{N}$ membranes which were used to route values, but also to compare values.

We are concerned in this section with the crucial step of constructing a comparator of two values, which can serve as a building block for a P system which can sort N values. However, we do this by keeping in mind the biological processes and biochemical reactions illustrated in Section 2.

The formalism we adopt is that of a P system with dynamic communication [8, 10], along the same general lines as the model proposed in [9]. The computation takes place according to a finite sequence R_μ of pairs $[E, rules]$. The rules are applied on the set E of directed edges between membranes.

The comparator P system we propose is illustrated in Figure 2.

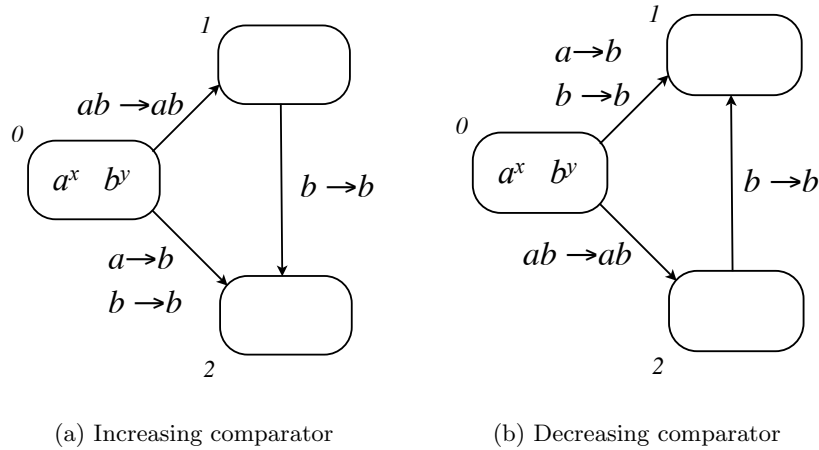

Fig. 1. A P system which sorts numbers x and y codified as occurrences of symbols a and b in membrane 0.

The formal definition of the P system which sorts ascending (Figure 1(a)) is the following:

$$\begin{aligned} \Pi = < V = \{a, b\}, \langle [a^x, b^y]_1, []_2, []_3 \rangle, \\ R_\mu = \{ \{(0, 1)\}, rules(0, 1) = \{ab \rightarrow ab\} \}. \\ \cdot \{ \{(0, 2), (1, 2)\}, rules(0, 2) = \{a \rightarrow b, b \rightarrow b\}, rules(1, 2) = \{b \rightarrow b\} \} > . \end{aligned}$$

At the beginning of the computation, x copies of a and y copies of b are loaded in membrane 0. The first pair of R_μ sends $\min(x, y)$ copies of ab into membrane 1. In the next step, the b symbols from membrane 1 are sent to membrane 2, while the remaining $\max(x, y) - \min(x, y)$ symbols of membrane 0 are rewritten to b and sent to membrane 2. At this point we have obtained $\min(x, y)$ as the number of occurrences of symbol a in membrane 1, and $\max(x, y)$ as number of occurrences of symbol b in membrane 2.

In our opinion the biological implementation probably could be done by the use of artificial lipid membranes in which appropriate membrane transporters (symporters, antiporters, ABC transporters, etc) have been included.

In the following, we put forward the design of a biological experiment which could in vitro implement such a comparator. The only modification of the proposed P system is that on edge (0, 2) the rules are no longer rewriting rules, but simply: $a \rightarrow a, b \rightarrow b$. In this case, we still obtain the maximum in membrane 2, except that now it is codified as the total number of occurrences of both symbols a and b .

The proposal comprises the following biological-biochemical-biophysical steps:

- i) in membrane 0 a specific type of enzyme which links one occurrence of a with one occurrence of b , thus forming one occurrence of ab ; the process is repeated until the number of ab occurrences equals the $\min(x, y)$;
- ii) in membrane 0 a uniporter protein transports all the occurrences of ab in membrane 1;
- iii) in membrane 1, a specific enzyme split all the occurrences of ab in a and b ;
- iv) in membrane 1, a membrane carrier, an antiporter, sends all the occurrences of b in membrane 2;
- iv') concurrently with step iv), in membrane 0 another membrane carrier, sends all remaining, unpaired occurrences of a or b in membrane 2, where there are already the bs arrived from membrane 1.

The particular biochemical nature of a and b , and transporters is in work. However is has to be said that the spatial relationships between these three types of membranes is important for computation and sorting.

A first generalization of this comparator to sort N numbers can be obtained by using $N + 1$ membranes. In membrane 0, number x_i is codified as numbers of occurrences of symbol a_i , with $1 \leq i \leq N$. In the first N steps, only one of the edges linking membranes 0 with 1, until 0 with N is active. The edge between membranes

0 and 1 contains the rule $a_1 \dots a_N \rightarrow a_1 \dots a_N$, the edge between membranes 0 and 2 contains all rules $\{a_1 \dots a_{i-1} a_{i+1} \dots a_N \rightarrow a_2 \dots a_N \mid 1 \leq i \leq N\}$, and so on. Finally, on the edge linking membrane 0 and membrane N the rules are $\{a_i \rightarrow a_N \mid 1 \leq i \leq N\}$. In the meantime, we also send from membrane 0 down to membrane N all symbols $a_2 \dots a_N, a_3 \dots a_N$, and so on, the only symbol being sent between membranes $N - 1$ and N being a_N . Having specified how to generate the rules attached to edges, the sequence of active edges has length N and is the following:

$$\{(0, 1)\}, \{(0, 2), (1, 2)\}, \{(0, 3), (2, 3)\}, \dots \{(0, N), (N - 1, N)\}.$$

In the end, after N steps, the sequence of numbers codified as occurrences of symbols in membranes 1 to N is increasing.

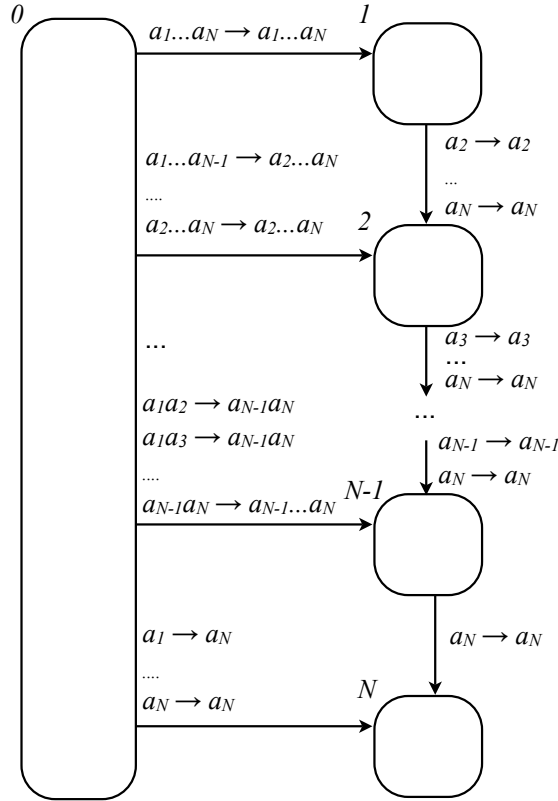

Fig. 2. A P system which sorts N numbers codified as occurrences of symbols $a_1 \dots a_N$ in membrane 0.

As mentioned before, one of the fastest parallel sorting algorithm is the bitonic sorting network. Following [14] it is customary to represent a network as an ordered set of N lines (wires) connected by a set of compare-exchange devices (*comparators*, for brevity). A comparator has two input terminals, a and b , and produces two output terminals c and d . If the comparator is increasing, then $c = \min(a, b)$ and $d = \max(a, b)$, while if the comparator is decreasing, $c = \max(a, b)$ and $d = \min(a, b)$. A bitonic sorting network for $N = 4$ is represented in Figure 3.

As we have built comparators of two elements, one can think of replacing each comparator of the bitonic network with the equivalent P system, and then connect the P systems according to the topology of the network. The rules according to these communication edges simply send all the symbols from the output membranes of the previous comparators to membrane 0 of the following one.

The P system described in Figure 4 has the following formal presentation:

$$\Pi_4 = \langle \{a, b, c, d\}, [a^x c^z]_0, \square_1, \square_2, [b^y d^t]_3, \square_4, \square_5, \dots, \square_{17}, R_\mu \rangle .$$

The sequence R_μ of pairs $[graph, rules]$ is given below, where by \cdot we denote sequential composition, and pairs grouped in the same set act in parallel.

$$\begin{aligned} R_\mu = & \{[(0, 1), ac \rightarrow ac][(3, 5), bd \rightarrow bd] \cdot \\ & \cdot \{[(1, 2), c \rightarrow c], [(0, 2), a \rightarrow c, c \rightarrow c], [(3, 4), b \rightarrow d, d \rightarrow d], [(5, 4), d \rightarrow d]\} \cdot \\ & \cdot \{[(1, 6), a \rightarrow a], [(2, 9), c \rightarrow c], [(4, 6), d \rightarrow d], [(5, 9), b \rightarrow b]\} \cdot \\ & \cdot \{[(6, 7), ad \rightarrow ad], [(9, 10), bc \rightarrow bc]\} \cdot \\ & \cdot \{[(6, 8), a \rightarrow d, d \rightarrow d], [(7, 8), d \rightarrow d], [(9, 11), b \rightarrow c, c \rightarrow c], [(10, 11), c \rightarrow c]\} \cdot \\ & \cdot \{[(7, 12), a \rightarrow a], [(8, 15), d \rightarrow d], [(10, 12), b \rightarrow b], [(11, 15), c \rightarrow c]\} \cdot \\ & \cdot \{[(12, 13), ab \rightarrow ab], [(15, 16), cd \rightarrow cd]\} \cdot \\ & \cdot \{[(12, 14), a \rightarrow b, b \rightarrow b], [(13, 14), b \rightarrow b], [(15, 17), c \rightarrow d, d \rightarrow d], [(16, 17), d \rightarrow d]\} . \end{aligned}$$

Thus, after 8 steps, the four numbers $\{x, y, z, t\}$ are sorted in ascending order in membranes labeled $\{13, 14, 16, 17\}$, codified with symbols $\{a, b, c, d\}$ respectively.

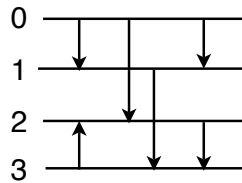

Fig. 3. A bitonic network of size $N = 4$.

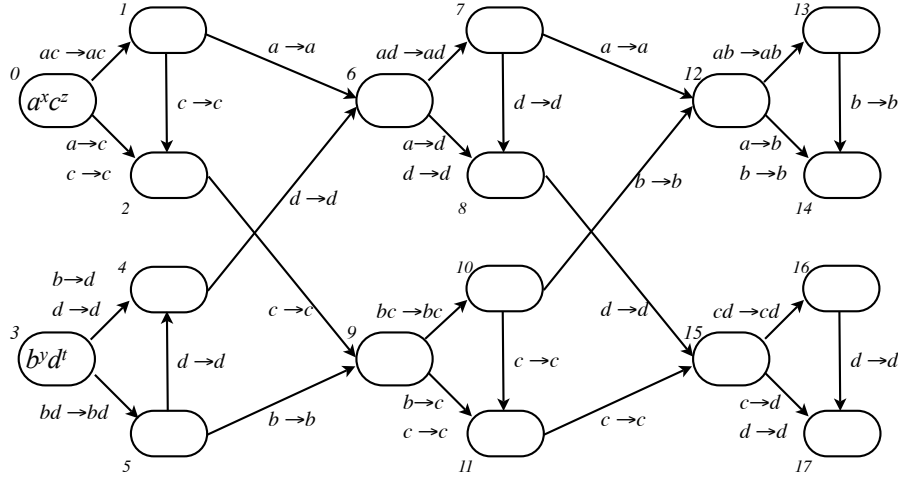

Fig. 4. A P system obtained from the bitonic sorting network of size 4 (Figure 3), in which each comparator has been replaced by a corresponding P system.

References

1. A. Alhazov, D. Sburlan: Static sorting P systems, Chapter 8 in Applications of Membrane Computing (G. Ciobanu, Gh. Păun, M.J. Pérez Jiménez Eds.), Springer, 2005.
2. I.I. Ardelean: The relevance of cell membranes for P systems. General aspects, Fundamenta Informaticae, 49, 1-3, pp. 35-43, 2002.
3. I.I. Ardelean: Molecular biology of bacteria and its relevance for P systems, Membrane Computing, LNCS 2597 (Gh. Păun, G. Rozenberg, A. Salomaa, C. Zandron, eds.), pp. 1-19, 2003.
4. I.I. Ardelean, Biological roots and applications of P systems. Further suggestions, H.J. Hoogeboom et al. (Eds.), LNCS 4361, pp. 117, 2006.
5. I.I. Ardelean, D. Besozzi, C. Manara: Aerobic respirations a bio-logic circuit containing molecular logic gates. Pre-Proc. of Fifth Workshop on Membrane Computing, WMC5 (G. Mauri, Gh. Păun, C. Zandron, eds.), Universita di Milano-Bicocca, June 14-16, pp. 119125, 2004.
6. J.J. Arulanandham: Implementing bead-sort with P systems, Unconventional Models of Computation 2002 (C.S. Calude, M.J. Dinneen, F. Peper Eds.), LNCS 2509, pp. 115-125, 2002.
7. K. Batcher: Sorting networks and their applications, Proc. of the AFIPS Spring Joint Computing Conf. 32, p. 307-314, 1968.
8. R. Ceterchi, M.J. Pérez Jiménez: On two-dimensional mesh networks and their simulation with P systems, LNCS 3365, pp. 259-277, 2005.
9. R. Ceterchi, M.J. Pérez Jiménez, A.I. Tomescu: Simulating the bitonic sort using P systems, G. Eleftherakis et al. (Eds.), WMC8 2007, LNCS 4860, pp. 172-192, 2007.
10. R. Ceterchi, C. Martín-Vide: Dynamic P systems, LNCS 2597, pp. 146-186, 2003.
11. R. Ceterchi, C. Martín-Vide: P Systems with communication for static sorting, GRLMC Report 26 (M. Cavaliere, C. Martín-Vide, Gh. Păun, eds.), Rovira i Virgili University, Tarragona, 2003.

12. G. Ciobanu, Gh. Păun, M.J. Pérez Jiménez (Eds.): Applications of Membrane Computing, Springer, 2006.
13. D.J.Kelly, G.H. Thomas: The tripartite ATP-independent periplasmic (TRAP) transporters of bacteria and archaea, *FEMS Microbiol. Rev.* 25, pp. 404-424, 2001.
14. D.E. Knuth: The art of computer programming, volume 3: sorting and searching, second ed. Redwood City, CA: Addison Wesley Longman, 1998.
15. S.E. Moya, J.L. Toca-Herrera: From hollow shells to artificial cells: biointerface engineering on polyelectrolyte capsules. *J. Nanosci. Nanotechnol.*, vol. 6, pp. 19, 2006.
16. V. Noireaux, A. Libchaber: A vesicle bioreactor as a step toward an artificial cell assembly. *PNAS*, 101, pp. 1766917674, 2004.
17. A. Ottova, H.T. Tien: The 40th anniversary of bilayer lipid membrane research. *Bioelectrochemistry*, 56, pp. 171173, 2002.
18. Gh. Păun: Computing with membranes (P systems): solving SAT in linear time, *Proc. Rom. Acad., series A*, 1, pp. 59-63, 2000.
19. Gh. Păun: From cells to computers: computing with membranes (P systems), *Biosystems*, 59, pp.139-158, 2001.

